

DATASHEET

**PAN BEAM PB 16HP | + VARIANTS**

*COMPACT, ACTIVE,  
DIGITALLY STEERABLE LINE ARRAY  
WITH BEAM STEERING TECHNOLOGY*

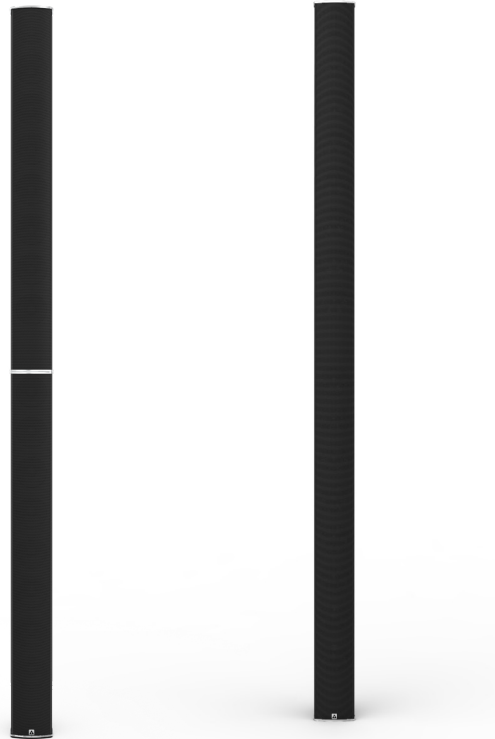

Illustration of variant split enclosure

Illustration of variant single enclosure

Illustration in colour option, see mechanical properties

The **Pan Beam PB 16HP** is a compact, active, digitally steerable line array with beam steering technology in an attractive design that has been developed for high-quality speech and music transmissions.

The **PB 16HP** features Pan Audio DSP and network functions such as Pan Net, AES/EBU and Dante. It is operated via user-friendly Windows software. The PB 16HP is connected to the computer via a Pan Net interface or via Dante. Digital signal processing from the Pan Audio DSP can be used to enter and control the sound and delay times in real time.

The **PB 16HP** can generate four highly directed sound beams which can be modified using various optimizers (max. SPL, SPL + min. sidelobes, min. sidelobes). Digital signal processing can be used to precisely adjust the vertical radiation angle and the tilt angle to the area to be filled with sound.

The **PB 16HP** is equipped with 16 specially manufactured 3.5" HQ drivers, DSP module and 16 digital amplifiers with a rated power of up to 100 watts each. A single PB 16HP module can cover a listening area of up to 35 meters, with speech intelligibility and sound pressure remaining virtually constant over the entire distance.

**EQUIPMENT / OPTIONS**



See last page for explanation of the symbols.

**APPLICATIONS**

Churches, mosques, museums, live PA, train stations, airports, sports facilities, legislative buildings, conference rooms, lecture halls, shopping centres, A/V presentation rooms

**FEATURES:**

High efficiency, integrated protection circuits, high speech intelligibility and music reproduction even in acoustically challenging environments, sleek and unobtrusive design, remote monitoring, two audio inputs

**INTEGRATED DSP CONTROL FOR:**

Adjustment of vertical radiation (coverage/tilt angle), 5-band parametric equalizer, volume control, internal delay up to 370 ms, connection to media controller possible, two independent line inputs with automatic priority switching

**MOUNTING ACCESSORIES**

For the **Pan Beam** series, a wide range of mounting accessories is available for fixed installation and mobile use.

**EVACUATION SYSTEMS**

The Pan Beam series can be integrated into voice alarm / electroacoustic emergency warning systems according to EN 50849.

All **Pan Beam** loudspeakers are designed, developed and manufactured in Germany by Pan Acoustics from high quality materials and according to strict criteria.



## TECHNICAL DATA PAN BEAM PB 16HP

### ACOUSTIC PROPERTIES

<b>Configuration:</b>	digitally steerable line array
<b>Frequency range:</b>	70 Hz - 18 kHz
<b>Equipment:</b>	16 x 3.5" HQ drivers
<b>Horizontal radiation pattern:</b>	130° (3 kHz), 70° (10 kHz)
<b>Vertical radiation pattern:</b>	3° - 40°, digitally steerable
<b>Number of beams:</b>	4
<b>Acoustic focus adjustable according to room length</b>	
<b>Tilt:</b>	-70° - +70° (digitally steerable)
<b>Focus distance:</b>	1 m up to 75 m
<b>Typical distance:</b>	35 m
<b>Maximum SPL:</b>	134 dB SPL* @ 1 m (calc.)   100 dB SPL @ 25 m
<b>Dynamic range:</b>	>105 dB

### ELECTRONIC PROPERTIES

<b>Amplifier output/type:</b>	up to 16 x 100 watts max (4 ohms) / digital PWM
<b>DSP:</b>	24 bit / 96 kHz sample rate
<b>Pan Net I/O:</b>	2 x etherCON
<b>Audio input via Pan Net:</b>	transformer balanced line level +4 dBu
<b>Power consumption:</b> Idle: max:	21 W @ 230 V 600 W @ 230 V
<b>Temperature range:</b>	0 °C to 40 °C ambient temperature
<b>Inrush current:</b>	< 50 A @ 230 V
<b>Power supply:</b>	85 V <sub>AC</sub> - 265 V <sub>AC</sub> , 47 Hz to 63 Hz
<b>Connection:</b>	IEC socket

### MECHANICAL PROPERTIES

<b>Enclosure:</b>	Aluminium profile
<b>Grille:</b>	Powder-coated perforated metal sheet
<b>Standard colours (with silver lids): (optional: lid in enclosure colour)</b>	RAL 9006 (aluminium), anodized RAL 9010 (white), silk matt RAL 9005 (black), silk matt
<b>Dimensions (H x W x D): Dimensions dG - variant (H x W x D):</b>	1812 x 107 x 118 [mm] 1806 x 107 x 118 [mm]
<b>Weight:</b>	11 kg (incl. electronics)
<b>Mounting accessories:</b>	Extensive range of mounting accessories available

\*under anechoic half-space conditions with DSP settings  
Frequency range: -10 dB under anechoic half-space conditions



## TECHNICAL DATA PAN BEAM PB 16HP | AES

### ACOUSTIC PROPERTIES

<b>Configuration:</b>	digitally steerable line array
<b>Frequency range:</b>	70 Hz - 18 kHz
<b>Equipment:</b>	16 x 3.5" HQ drivers
<b>Horizontal radiation pattern:</b>	130° (3 kHz), 70° (10 kHz)
<b>Vertical radiation pattern:</b>	3° - 40°, digitally steerable
<b>Number of beams:</b>	4
<b>Acoustic focus adjustable according to room length</b>	
<b>Tilt:</b>	-70° - +70° (digitally steerable)
<b>Focus distance:</b>	1 m up to 75 m
<b>Typical distance:</b>	35 m
<b>Maximum SPL:</b>	134 dB SPL* @ 1 m (calc.)   100 dB SPL @ 25 m
<b>Dynamic range:</b>	>105 dB

### ELECTRONIC PROPERTIES

<b>Amplifier output/type:</b>	up to 16 x 100 watts max (4 ohms) / digital PWM
<b>DSP:</b>	24 bit / 96 kHz sample rate
<b>Pan Net I/O:</b>	2 x etherCON
<b>Audio input via Pan Net:</b>	digital 44.1 / 48 / 96 / 192 kHz (sample rates) 1 x analog audio
<b>Power consumption:</b> Idle: max:	21 W @ 230 V 600 W @ 230 V
<b>Temperature range:</b>	0 °C to 40 °C ambient temperature
<b>Inrush current:</b>	< 50 A @ 230 V
<b>Power supply:</b>	85 V <sub>AC</sub> - 265 V <sub>AC</sub> , 47 Hz to 63 Hz
<b>Connection:</b>	IEC socket

### MECHANICAL PROPERTIES

<b>Enclosure:</b>	Aluminium profile
<b>Grille:</b>	Powder-coated perforated metal sheet
<b>Standard colours (with silver lids): (optional: lid in enclosure colour)</b>	RAL 9006 (aluminium), anodized RAL 9010 (white), silk matt RAL 9005 (black), silk matt
<b>Dimensions (H x W x D): Dimensions dG - variant (H x W x D):</b>	1812 x 107 x 118 [mm] 1806 x 107 x 118 [mm]
<b>Weight:</b>	11 kg (incl. electronics)
<b>Mounting accessories:</b>	Extensive range of mounting accessories available

\*under anechoic half-space conditions with DSP settings  
Frequency range: -10 dB under anechoic half-space conditions



## TECHNICAL DATA PAN BEAM PB 16HP-D (DANTE)

### ACOUSTIC PROPERTIES

<b>Configuration:</b>	digitally steerable line array
<b>Frequency range (-10 dB):</b>	70 Hz - 18 kHz
<b>Equipment:</b>	16 x 3.5" HQ drivers
<b>Horizontal radiation pattern:</b>	130° (3 kHz), 70° (10 kHz)
<b>Vertical radiation pattern:</b>	3° - 40°, digitally steerable
<b>Number of beams:</b>	4
<b>Acoustic focus adjustable according to room length</b>	
<b>Tilt:</b>	-70° - +70° (digitally steerable)
<b>Focus distance:</b>	1 m up to 75 m
<b>Typical distance:</b>	35 m
<b>Maximum SPL:</b>	134 dB SPL* @ 1 m (calc.)   100 dB SPL @ 25 m
<b>Dynamic range:</b>	>105 dB

### ELECTRONIC PROPERTIES

<b>Amplifier output/type:</b>	up to 16 x 100 watts max (4 ohms) / digital PWM
<b>DSP:</b>	24 bit / 96 kHz sample rate
<b>Network I/O:</b>	1 x etherCON primary 1 x etherCON secondary 1 x etherCON Pan Net Link
<b>Audio input via Dante:</b>	44.1 / 48 / 96 sample rate
<b>Power consumption:</b>	
Idle:	24 W @ 230 V
max:	600 W @ 230 V
<b>Temperature range:</b>	0 °C to 40 °C ambient temperature
<b>Inrush current:</b>	< 50 A @ 230 V
<b>Power supply:</b>	85 V <sub>AC</sub> - 265 V <sub>AC</sub> , 47 Hz to 63 Hz
<b>Connection:</b>	IEC socket

### MECHANICAL PROPERTIES

<b>Enclosure:</b>	Aluminium profile
<b>Grille:</b>	Powder-coated perforated metal sheet
<b>Standard colours (with silver lids): (optional: lid in enclosure colour)</b>	RAL 9006 (aluminium), anodized RAL 9010 (white), silk matt RAL 9005 (black), silk matt
<b>Dimensions (H x W x D):</b>	1812 x 107 x 118 [mm]
<b>Dimensions dG - variant (H x W x D):</b>	1806 x 107 x 118 [mm]
<b>Weight:</b>	11 kg (incl. electronics)
<b>Mounting accessories:</b>	Extensive range of mounting accessories available

\*under anechoic half-space conditions with DSP settings  
Frequency range: -10 dB under anechoic half-space conditions

TECHNICAL DRAWING PB 16HP (VARIANTS)

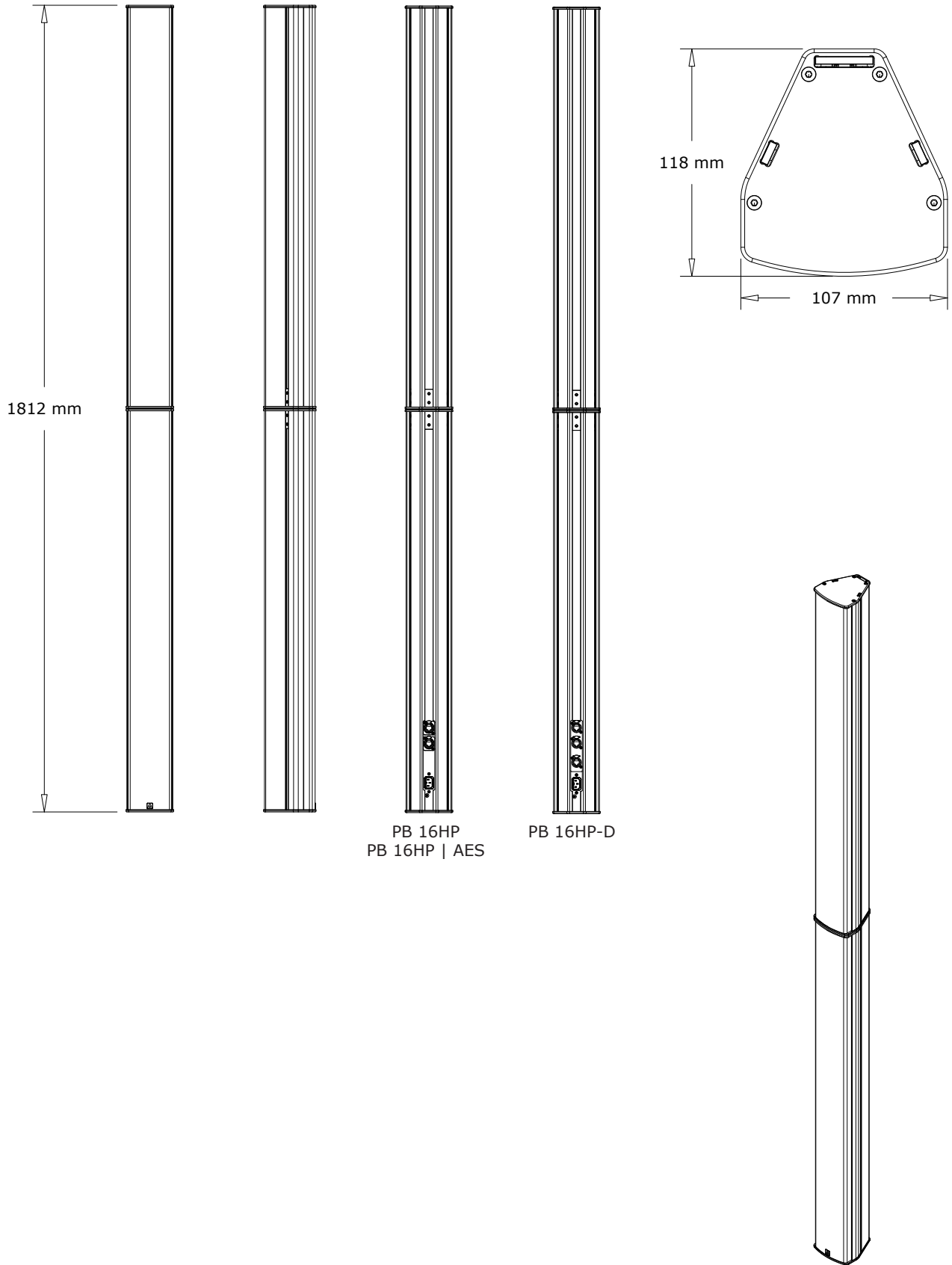

**TECHNICAL DRAWING PB 16HP (dG) (VARIANTS)**

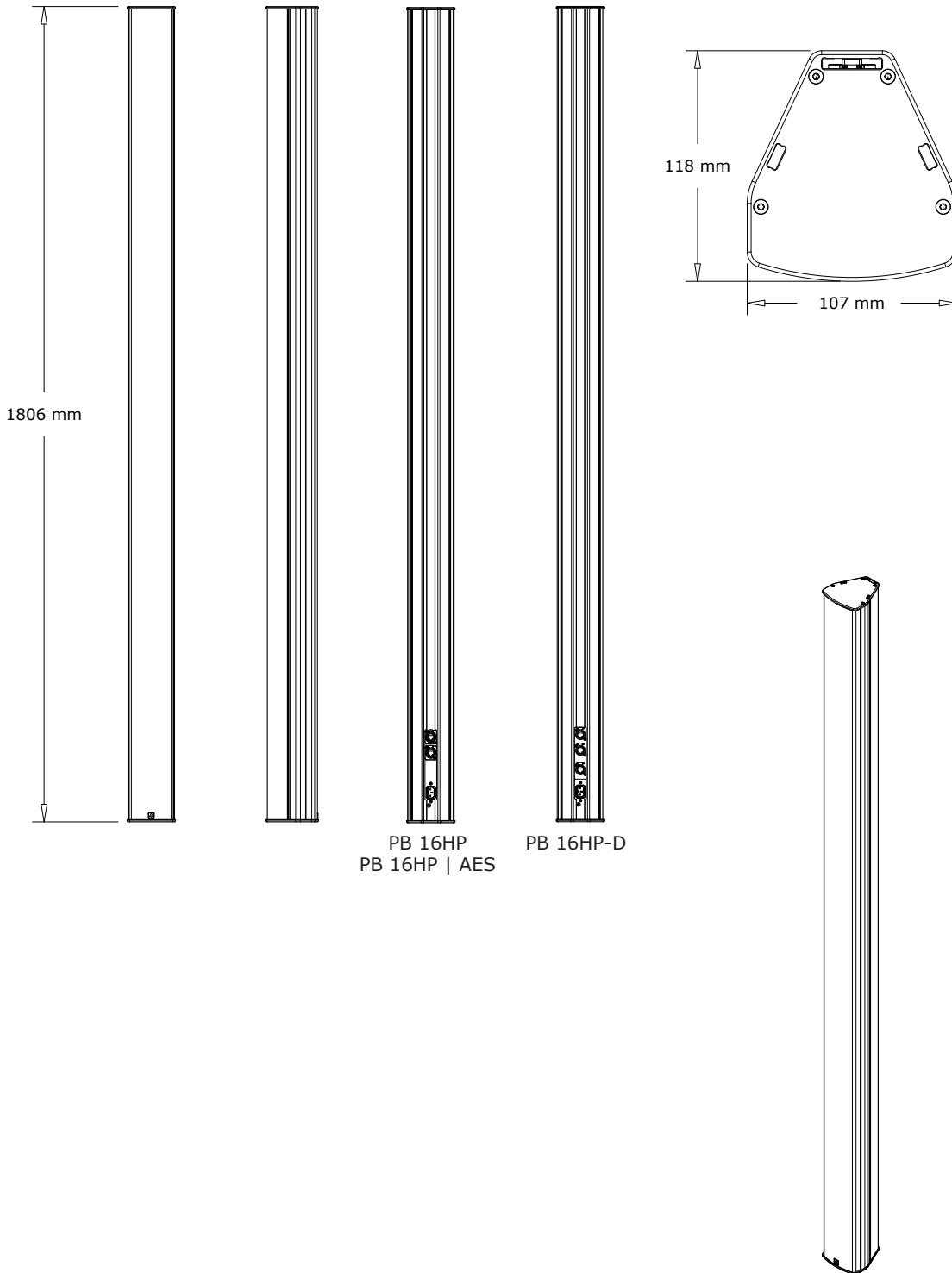

PB 16HP  
PB 16HP | AES

PB 16HP-D

**EQUIPMENT / OPTIONS AT GLANCE – PAN BEAN SERIES**



**Customised painting/colouring** within the RAL colour range. Other colour ranges such as RAL design, Pantone, etc. are available on request.



**Analogue audio inputs** with balanced signal routing.



**Digital Dante audio network** including AES67 support. Redundant network structure with Pan Net control.



**Pilot tone evaluation** for integration in SAA/ENS systems.



**General Purpose Output (GPO)** Switchable contact, e.g. for status request via downstream media control.



**DC input** for operation on emergency power supplies.



**Accessories** such as wall, tripod and ceiling mounts, different interfaces, connection cables, weather protection hoods and connection sets are available.



**Looks good, sounds good.** Pan Acoustics' products are defined by natural sound and attractive design.

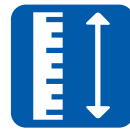

**Made-to-measure enclosure** of the loudspeaker is possible. The enclosure dimensions of the Pan Beam series can be customised.

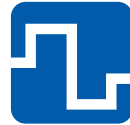

**Digital audio inputs** support 2 x AES/EBU (AES3).



**100 V audio inputs** with different power taps.

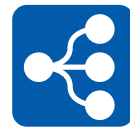

**Pan Net** Pan Acoustics' own control and monitoring protocol.



**Priority switching** Automatic switching of the audio inputs e.g. between programme and announcement.



**Weatherproofing** of the loudspeakers in accordance with protection classes IP54 or IP65 (depending on the model) is possible.



**Ball impact resistance**

Some equipment features cannot be combined. For information about which features can be combined with each other, please send an e-mail to [sales@pan-acoustics.de](mailto:sales@pan-acoustics.de).

**Our quality promise**

Pan Acoustics stands by its products and gives up to **10 years warranty** on its loudspeakers for any material or manufacturing defects. New products manufactured in accordance with protection classes IP54 and IP65 as well as digital audio interfaces (Dante®) from Audinate Pty Ltd and rechargeable batteries are excluded from the 10-year warranty. A warranty period of 3 years is granted for loudspeakers in accordance with protection classes IP54 and IP65.

