

DATASHEET

WALL/CEILING MOUNT FOR P/PB 04 WITH ACCESS PROTECTION



The **Wall/Ceiling Mount for P/PB 04 with Access Protection** from the **Pan Accessories series** has been developed to accommodate the P/PB 04 models of the **Pan Beam and Pan Speaker loudspeaker system range**.

The accessories are made of stainless steel and designed for safe mounting of the above loudspeakers on wall and ceiling surfaces. In addition, they prevent access to the speaker connections by protecting them by a cover that can only be (dis)mounted using tools. The connection cables of the loudspeaker can be routed to the outside via outlets in the mount.

The mount provides a speaker swivel range of 60° (+15°/-45°). Various mounting points permit the precise positioning of the mount on walls or ceilings.

All **Pan Acoustics** loudspeakers and the corresponding accessories are designed, developed and manufactured in Germany by Pan Acoustics according to strict criteria and with high-quality materials.

EQUIPMENT / OPTIONS



See last page for explanation of the symbols.

APPLICATIONS

Wall and ceiling mounting

TECHNICAL DATA: WALL/CEILING MOUNT FOR P/PB 04

MECHANICAL PROPERTIES

Enclosure:	Stainless steel
Speaker swivel range	60° (+15°/-45°)
Standard colours:	Stainless steel RAL 9010 (white), silk matt RAL 9005 (black), silk matt
Dimensions without loudspeaker (H x W x D)	115 x 295 x 83 [mm]
Weight:	1.7 kg

TECHNICAL DRAWING

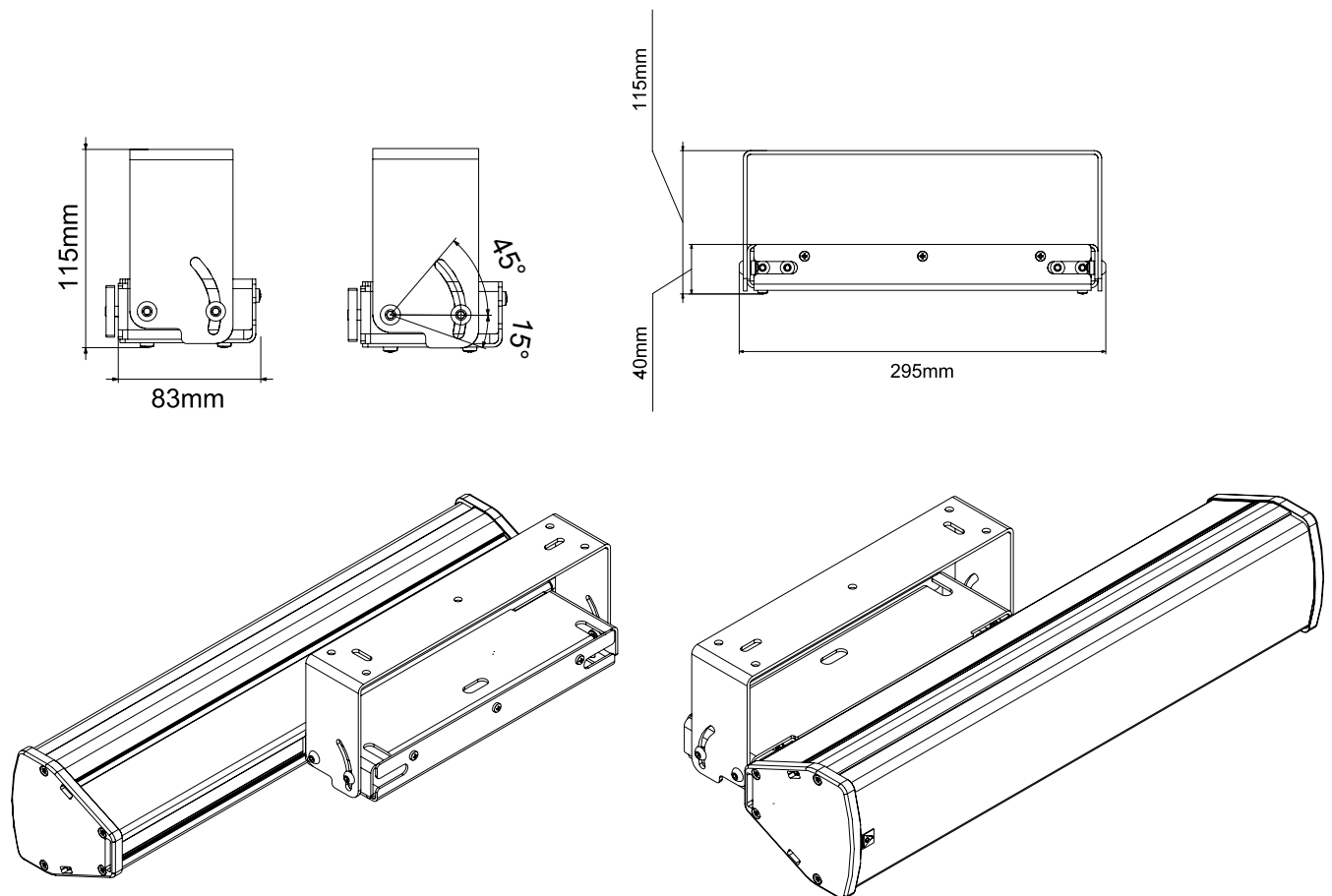



EQUIPMENT / OPTIONS AT GLANCE – ACCESSORIES



Customised painting/colouring within the RAL colour range. Other colour systems such as RAL design, Pantone, etc. are available on request.



Looks good, sounds good. Pan Acoustics' products are defined by natural sound and attractive design.

Some equipment features cannot be combined. For information about which features can be combined with each other, please send an e-mail to vertrieb@pan-acoustics.de.

Our quality promise

Pan Acoustics stands by its products and gives up to **10 years warranty** on its loudspeakers for any material or manufacturing defects. New products manufactured in accordance with protection classes IP54 and IP65 as well as digital audio interfaces (Dante®) from Audinate Pty Ltd and rechargeable batteries are excluded from the 10-year warranty. A warranty period of 3 years is granted for loudspeakers in accordance with protection classes IP54 and IP65.

