

DATASHEET

TRIPOD MOUNT
VARIO SYSTEM



The **Pan Vario System** from the **Pan Accessories series** is a mounting system for mobile use and flexible mounting.

The L-shaped **Vario tripod mount** for loudspeaker tripods with a diameter of 36 mm permits the easy mounting of loudspeakers from the Pan AMT, Pan Speaker or Pan Beam series with a weight of up to 13 kg and a length of up to 1.8 m on tripods and their vertical adjustment by means of a toothed clamping element.

The **Vario tripod mount** is attached without the use of tools to the Vario clamp bracket for P 261-AMT systems or via the Vario magic block by means of two ball locking bolts.

The L-shape of the bracket protects the signal connections on the loudspeaker from unauthorised access.

The accessory is made of steel and can be powder-coated to match the colour scheme of the loudspeaker.

EQUIPMENT / OPTIONS



See last page for explanation of the symbols.

APPLICATIONS

Tripod, hoist and joist mounting

All **Pan Acoustics** loudspeakers and the corresponding accessories are designed, developed and manufactured in Germany by Pan Acoustics according to strict criteria and with high-quality materials.

VARIO TRIPOD MOUNT

MECHANICAL PROPERTIES

Material:	Steel
Load capacity:	max. 13 kg
Standard colours:	RAL 9005 (black), silk matt RAL 9010 (white), silk matt
Dimensions without loudspeaker (H x W x D):	502 x 100 x 173 [mm]
Weight:	1.8 kg

TECHNICAL DRAWING

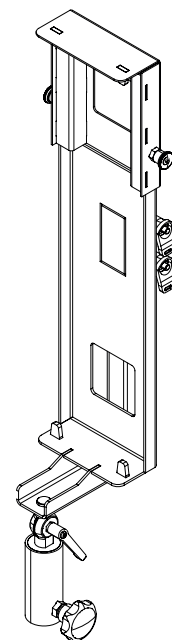
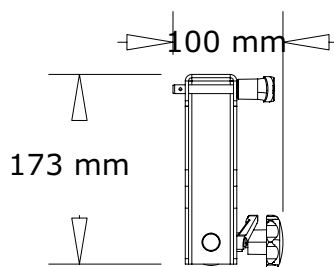
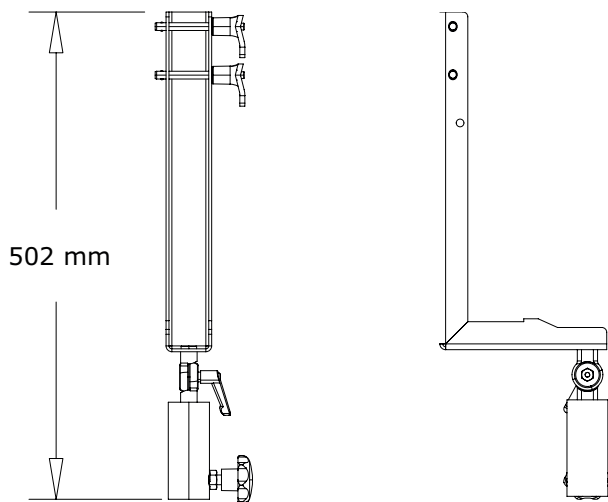

Illustration of Vario system including clamp bracket and tripod mount



EQUIPMENT / OPTIONS AT GLANCE – ACCESSORIES



Customised painting/colouring within the RAL colour range. Other colour systems such as RAL design, Pantone, etc. are available on request.



Looks good, sounds good. Pan Acoustics' products are defined by natural sound and attractive design.

Some equipment features cannot be combined. For information about which features can be combined with each other, please send an e-mail to sales@pan-acoustics.de.

Our quality promise

Pan Acoustics stands by its products and gives up to **10 years warranty** on its loudspeakers for any material or manufacturing defects. New products manufactured in accordance with protection classes IP54 and IP65 as well as digital audio interfaces (Dante®) from Audinate Pty Ltd and rechargeable batteries are excluded from the 10-year warranty. A warranty period of 3 years is granted for loudspeakers in accordance with protection classes IP54 and IP65.

