

DATASHEET

FIXED WALL MOUNT
FOR P / PB XX LOUDSPEAKER SYSTEMS



The **fixed wall mount for P / PB xx loudspeaker systems** from the **Pan Accessories series** can be used to accommodate the P / PB xx models of the **Pan Beam, Pan Speaker, Pan 2-Line and Pan AMT loudspeaker system range**.

The accessory is made of steel and can be powder-coated to match the colour scheme of the loudspeaker. The wall mount is designed for secure mounting of the loudspeakers to wall surfaces and consists of two parts for easy installation. In addition, the wall mount can only be dismantled using tools. The wall mount can be moved freely over the length of the loudspeaker via the (included) slot nut to be mounted in the rear slot of the loudspeaker. This permits to flexibly adjust the height of the loudspeaker.

The wall mount provides a vertical speaker swivel range of 4° (0°/-4°), e.g. to compensate for unevenness in the wall.

The number of mounts required per loudspeaker varies and depends on the length of the loudspeaker, see table "Overview of PA mounts".

EQUIPMENT / OPTIONS



See last page for explanation of the symbols.

APPLICATIONS

Wall mounting

All **Pan Acoustics** loudspeakers and the corresponding accessories are designed, developed and manufactured in Germany by Pan Acoustics according to strict criteria and with high-quality materials.

TECHNICAL DATA: FIXED WALL MOUNT

MECHANICAL PROPERTIES

Material:	Steel
Speaker swivel range Vertical: Horizontal:	4° (0°/-4°) 0°
Load capacity:	max. 13 kg
Standard colour:	Galvanised steel
Dimensions without loudspeaker (H x W x D):	120 x 80 x 40 [mm]
Weight:	0.7 kg

TECHNICAL DRAWING

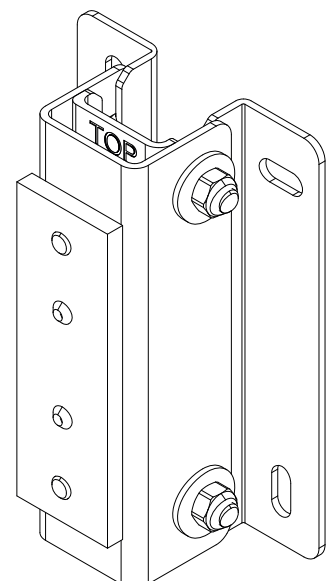
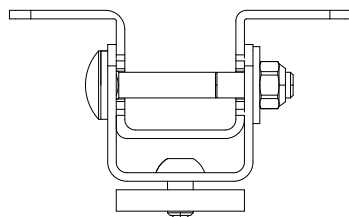
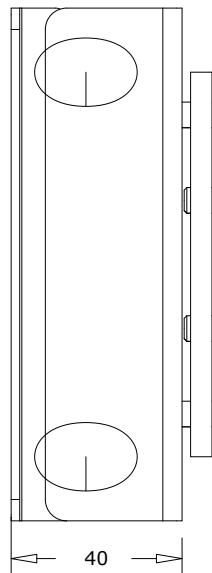
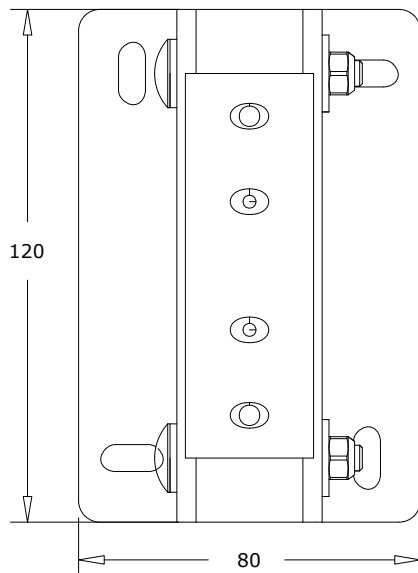



EQUIPMENT / OPTIONS AT GLANCE – ACCESSORIES



Customised painting/colouring within the RAL colour range. Other colour systems such as RAL design, Pantone, etc. are available on request.



Looks good, sounds good. Pan Acoustics' products are defined by natural sound and attractive design.

Some equipment features cannot be combined. For information about which features can be combined with each other, please send an e-mail to sales@pan-acoustics.de.

Our quality promise

Pan Acoustics stands by its products and gives up to **10 years warranty** on its loudspeakers for any material or manufacturing defects. New products manufactured in accordance with protection classes IP54 and IP65 as well as digital audio interfaces (Dante®) from Audinate Pty Ltd and rechargeable batteries are excluded from the 10-year warranty. A warranty period of 3 years is granted for loudspeakers in accordance with protection classes IP54 and IP65.

