

DATASHEET

DANTE INTERFACE - PAN NET
PAN NET INTERFACE



The **DANTE INTERFACE - PAN NET** is an interface for integrating AES/EBU-capable devices from the Pan Beam and Pan Subwoofer series into a Dante network.

The interface has two RJ45 gigabit network connections (Dante Primary / Dante Secondary) as well as an RJ45 Pan Net connection. This connection provides two-channel digital audio (AES/EBU) and the Pan Net control protocol for setup and monitoring.

The connected speakers are programmed via the Dante network using a PC with „Pan Beam Setup“ software installed.

The interface is powered via an external power supply unit with a two-pin barrel-type power plug.

EQUIPMENT / OPTIONS



See last page for explanation of the symbols.

APPLICATIONS

Pan Net Converter (Dante -> AES/EBU incl. control data)

All **Pan Acoustics** loudspeakers and their accessories are developed, designed and manufactured in Germany by Pan Acoustics according to strict criteria and with high-quality materials.

TECHNICAL DATA

ELECTRICAL PROPERTIES

| | |
|--|---|
| Network I/O: | 1 x etherCON Primary 1 x etherCON Secondary 1 x etherCON Pan Net-Link |
| Audio input via Dante: | 44.1 / 48 / 96 Sample rate |
| Supported Dante network modes: | Switch / redundancy mode |
| Pan Link output: | AES/EBU (2 Channel), Pan Net Control |
| Supported cable length: (Device -> Device) | up to 100m* |
| Temperature range: | 0 °C to +40 °C Ambient temperature |
| Power consumption: | 8W |
| Power supply: | 11...36 VDC |
| Connection: | Two-pin barrel-type plug 5.5 x 2.1 [mm] // (external power supply)** |

MECHANICAL PROPERTIES

| | |
|--------------------------------|--------------------------|
| Enclosure: | Aluminium profile casing |
| Colour: | Aluminium RAL 9006 |
| Dimensions (H x B x T): | 164 x 80 x 46 [mm] |
| Weight: | 1.0 kg |
| Optional accessories: | IP protection housing |

* depending on the used cable

** not included in the scope of delivery

TECHNICAL DRAWING

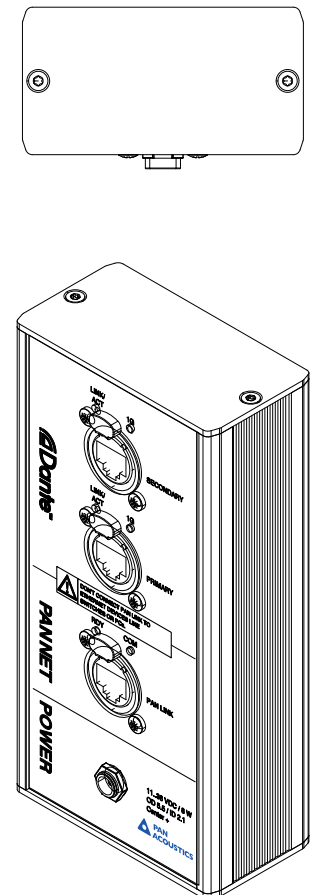
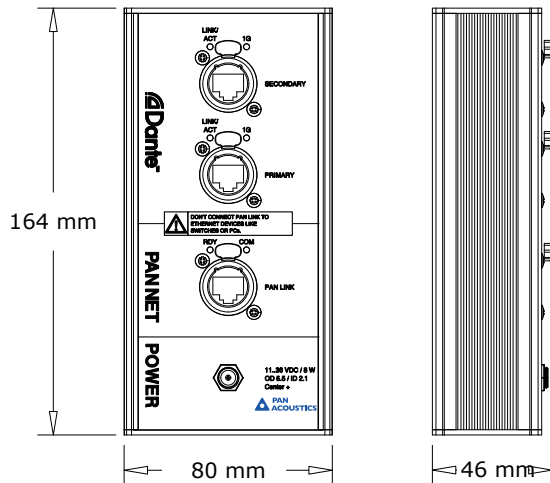

EQUIPMENT / OPTIONS AT GLANCE - ACCESSORIES PAN NET



Digital audio network DANTE
incl. AES67 support.
Redundant network structure with Pan Net control.



Digital audio inputs support
2 x AES/EBU (AES3).

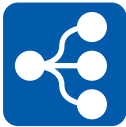

Pan Net
Pan Acoustics' own control and monitoring protocol.



Accessories such as wall, tripod and ceiling mounts, different interfaces, connection cables, weather protection hoods and connection sets are available.



Looks good, sounds good.
Pan Acoustics' products are defined by natural sound and attractive design.

Some equipment features cannot be combined. For information about which features can be combined with each other, please send an e-mail to sales@pan-acoustics.de.

Our quality promise

Pan Acoustics stands by its products and gives up to **10 years warranty** on its loudspeakers for any material or manufacturing defects. New products manufactured in accordance with protection classes IP54 and IP65 as well as digital audio interfaces (Dante®) from Audinate Pty Ltd and rechargeable batteries are excluded from the 10-year warranty. A warranty period of 3 years is granted for loudspeakers in accordance with protection classes IP54 and IP65.

